



MANUAL GEARBOX CUTAWAY MODEL

A2

Product number

AE410990M



Highly detailed educational cutaway trainer shows a 5-speed manual transmission with one reverse gear. This model features a fully exposed gear assembly, including gears, shafts, and synchronizers, mounted on a mobile stand for flexible classroom use.

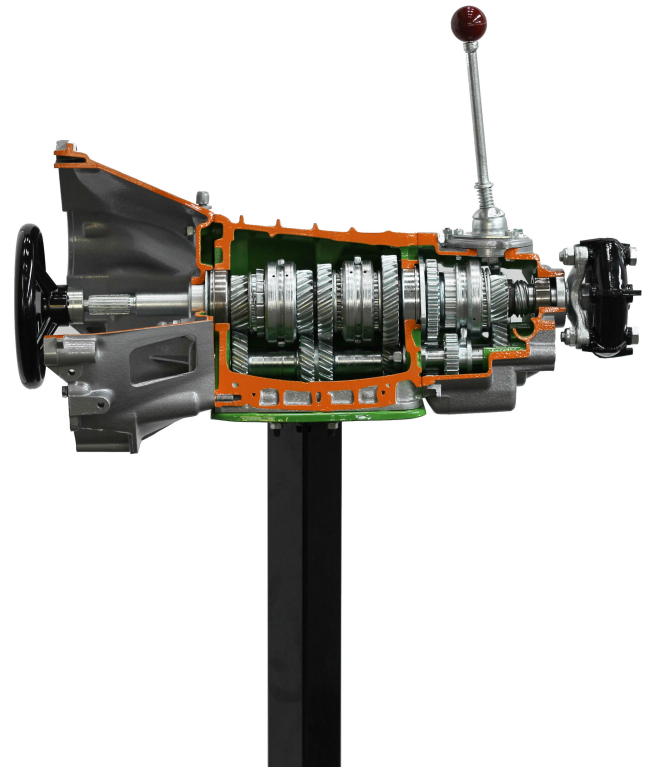

Features

- OEM based 5-speed gearbox Includes five forward gears and one reverse gear, representing common configurations in manual transmissions.
- Gear changes are simulated using a handwheel, providing an interactive learning experience.
- Exposes internal components such as gears, shafts, and synchronizers for detailed study.
- Mounted on a wheeled stand for ease of movement and positioning in different learning environments.



Value for Students

- The cutaway design allows for a clear view of internal gearbox components, including gears, shafts, synchronizers, and bearings. Students can observe and study the gear engagement process and the mechanics of shifting between gears.
- Operate the gearbox manually using the handwheel to select different speeds and reverse. This hands-on interaction helps in understanding the physical actuation of gear changes and the engagement/disengagement of gears.
- Gain practical insights into the working principles of a manual transmission system, including gear ratios, the role of synchronizers in smooth shifting, and the function of various components such as the input shaft, output shaft, and countershaft.
- The model is mounted on a wheeled stand for easy movement and positioning within a classroom or training environment. This facilitates group instruction and individual hands-on practice.



Value for Instructors

- The cutaway model offers a clear, unobstructed view of the internal workings of a manual transmission, making it an ideal tool for demonstrating the principles of gearbox operation.
- Uses OEM components for easy, safe, and realistic training that mimics real car.
- Utilize the handwheel operation to demonstrate gear changes, providing students with a tangible understanding of manual transmission mechanics.
- The model's mobility allows for flexible classroom integration, enabling easy relocation for various instructional setups and scenarios.
- The trainer's design focuses on practical learning, ensuring students gain real-world experience with gearbox components and operation.

Specifications

- Dimensions: 800 x 600 x 1200 mm (31.50 in x 23.62 in x 47.24 in)
- Weight: approx. 50 kg (110 lb)
- Product number: AE410990M