



ENGINE WITH MULTI-POINT ELECTRONIC INJECTION, TURBOCHARGED AND GEARBOX

A1/A2

Product number
AE44808E



Fully functional cutaway model featuring a 16-valve 4-cylinder engine with a turbocharger, multipoint electronic injection, and a front-drive 5-speed gearbox plus reverse. The model includes a differential integrated with the engine and transmission system, offering a comprehensive educational tool designed for hands-on learning. Operating electrically at 220 volts at a reduced speed, it ensures safe and detailed observation of key mechanical and electrical systems. Equipped with DOHC twin overhead camshaft, vibration-damping balancing shafts, turbocharger, and water cooling, it gives students direct insight into modern automotive engine components and their interactions. The cutaway design reveals internal structures, enabling detailed observation of how components are constructed and operate together.

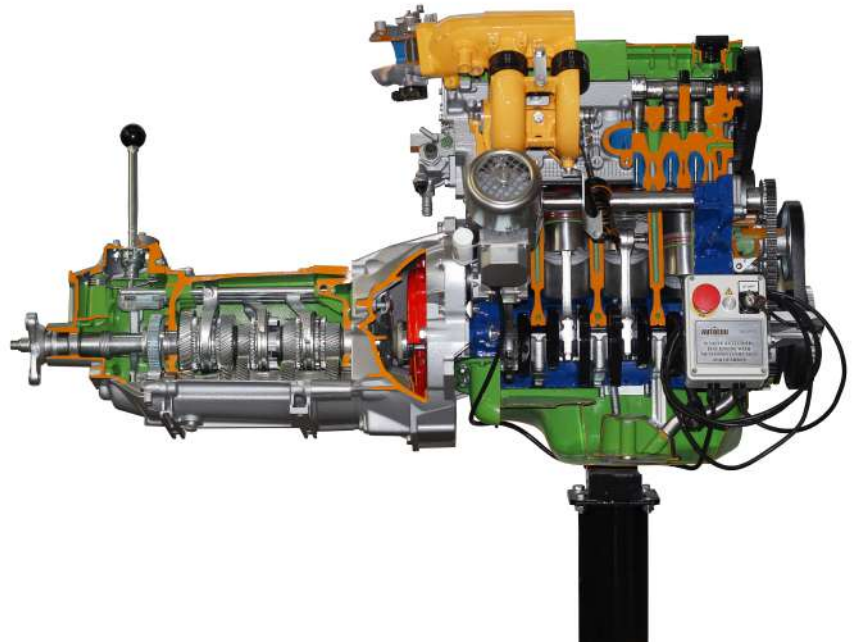

Features

- 4-cylinder engine with multipoint electronic injection system and turbocharger for realistic fuel management and forced induction training.
- DOHC twin overhead camshaft, providing an advanced look at camshaft operation and timing.
- Gearbox with 5 forward speeds and reverse, combined with an integrated differential for transmission and drivetrain training.
- Cutaway model with color-coded sections to highlight key engine components and systems.
- Operates electrically at 220 volts with reduced speed to enhance safe observation of working parts.
- Equipped with a 12-volt alternator, ignition control unit, and membrane clutch for comprehensive mechanical and electrical learning opportunities.
- Integrated balancing shafts and turbocharger to demonstrate vibration reduction and forced induction techniques in modern engines.



Value for Students

- 16-valve engine with turbocharger, exposing students to common automotive systems, including multipoint electronic injection, turbocharging, and advanced valve operation.
- Observation of the engine's mechanical components, such as the DOHC twin overhead camshaft, turbocharger, and balancing shafts, fostering an understanding of camshaft operations, forced induction, and balancing techniques.
- Gear transmission mechanisms, 5-speed front-drive gearbox with reverse.
- The cutaway design, with professionally painted and chromed sections, allows students to clearly visualize lubrication circuits, cooling pathways, and fuel system functioning, providing a visual, interactive learning experience. It also demonstrates how each component is constructed internally and how different parts interact within the engine.



Value for Instructors

- Utilizes OEM components for accurate, real-world automotive education, replicating the operational conditions of a standard vehicle.
- Enables step-by-step demonstrations of engine functioning, covering everything from ignition and fuel injection to mechanical operation of the gearbox and turbocharger.
- Safe and hands-on learning through reduced-speed electrical operation, making it easier to control and explain engine processes during lectures.
- Provides a clear visual distinction between various engine sections with color-coded parts, which aids in effective teaching, making it easier to explain specific functions and systems.
- Integrated stand with wheels allows the equipment to be moved and positioned conveniently, supporting flexible classroom layouts and facilitating collaborative learning.

Specifications

- Engine type: 4-cylinder, 16 valve with turbocharger
- Displacement: 2000 cu. cm/1600 cc
- Power supply: 220-volt electrical operation
- Gearbox: 5 forward speeds + reverse
- Dimensions: 160 x 86 x 100 cm (62.99 x 33.86 x 39.37 in)
- Weight: 195 kg (429.90 lbs)
- Additional features: Chromed, plated, and galvanized components for durability
- Product number: AE34807E

